



MODEL 001 & 002 FLOWMETER OPERATING MANUAL



Document ID 001813B | issue: 1.3

Date: February 2024

This confidential document was prepared by the staff of Valeport Limited, the Company, and is the property of the Company, which also owns the copyright therein. All rights conferred by the law of the copyright and by virtue of international copyright conventions are reserved to the Company. This document must not be copied, reprinted or reproduced in any material form, either wholly or in part, and the contents of this document, and any method or technique available there from, must not be disclosed to any other person whatsoever without the prior written consent of the Company.

© 2024 Valeport Ltd

Valeport Ltd
St Peter's Quay
Totnes TQ9 5EW
United Kingdom

Phone: +44 1803 869292
email: sales@valeport.co.uk
Web: www.valeport.co.uk

As part of our policy of continuous development, we reserve the right to alter, without prior notice, all specifications, designs, prices and conditions of supply for all our equipment.

Valeport Limited
St. Peter's Quay, Totnes,
Devon TQ9 5EW UK

+44 (0) 1803 869292
sales@valeport.co.uk
www.valeport.co.uk

VAT No: GB 165 8753 67
Registered in England No: 1950444



TABLE OF CONTENTS

1	Design & Configuration	4
1.1	Basic Design.....	4
1.2	Operational Use.....	4
2	Assembly Instructions.....	5
2.1	Wading Set.....	5
2.2	Suspension Set.....	5
3	Maintenance Instructions	6
3.1	To replace an Impeller.....	6
3.1.1	To remove Impeller	6
3.1.2	To replace Impeller.....	6
3.2	To Replace an Impeller Shaft.....	7
3.3	To Replace a Reed Switch Assembly.....	7
3.4	To Test the Free Running of the Impeller Assembly	7
4	Operation with 0012B Control Display Unit.....	8
4.1	Introduction	8
4.1.1	Physical Specification	8
4.1.2	Connectors	8
4.1.3	Measurement Methods	8
5	Operation.....	10
5.1	Switch On	10
5.2	Running the Model 0012B.....	10
5.3	Setting Up Running Mode	12
5.4	Changing Sampling Period	12
5.5	Options Menu.....	13
5.6	Logging Menu	14
5.6.1	Change Date\Time.....	14
5.6.2	Viewing Stored Data.....	15
5.6.3	Extracting Data.....	15
5.7	User Calibration Coefficients	16
5.8	Reading Calibration Coefficients.....	16
5.9	Setting Calibration Coefficients.....	17
5.10	Replacement Impeller (Orange not Yellow).....	17
5.10.1	General Control Codes #000 - #014.....	18
5.10.2	Table 1: Calibration Function Numbers and Meaning	18
5.10.3	How to Program Calibration Coefficients.	18
6	Flowmeter Spares.....	21
7	Figures	22
7.1	Figure 1 - Sectional Diagram BFM001	22
7.2	Figure 2 - BFM001 Impeller Shaft Setting	23
7.3	Figure 3 - Sectional Diagram of BFM002.....	24
7.4	Figure 4 - BFM002 Impeller Shaft Setting	25
7.5	Figure 5 - Reed Switch Assembly	26
8	EU Declaration of Conformity - CE Marking.....	27
	Appendices.....	28
A-1	Group Calibration of the 8011 Series Impeller	28
A-1.1	Definition.....	28
A-1.2	Application.....	28
A-1.3	Recognition.....	28

A-1.4	Rating Equations and Table	28
A-1.5	Reliability.....	29
A-1.6	Individual Calibration.....	29
A-1.7	Further Details.....	29
A-2	Group Calibration of the 1178 Series Impeller	30
A-2.1	Summary	30
A-2.2	Method and Result of Group Calibration.....	31
	A-2.2.1 Extract from Full Report.....	31
	A-2.2.2 Acknowledgements.....	31

1 DESIGN & CONFIGURATION

The Valeport "Braystoke flowmeter" (BFM) 001 and BFM002 flowmeters have been designed to withstand long periods of operation underwater and to need little maintenance with as few moving parts as possible. They are designed to accurately measure water velocity in open channels with flows varying from 0.03 m/s to 10 m/s (BFM001), or 0.05m/s to 5m/s (BFM002). The calibration of the meters is based upon Group Calibrations carried out by HR Wallingford to standards established by the British Standards Institution.

The flowmeters are available with both Wading and Suspension Sets to allow the equipment to be employed in a wide variety of applications.

1.1 BASIC DESIGN

Refer to [Figure 1 \(BFM001\)](#) and [Figure 3 \(BFM002\)](#).

The basic principle of the Meter is to open and close a reed switch by rotating magnets around it, to open and close a circuit producing a pulse. The pulse count is displayed on one of the liquid crystal displays in the Control Unit. A bias magnet fitted into the meter hub produces a strong magnetic field and allows only one pulse per impeller revolution. The only moving part of the Meter is the neutrally buoyant impeller, which houses the magnets. The bearings fitted to this impeller are made from PTFE plastic and are water lubricated. Since the impeller has very little weight in water, the load on the bearings is negligible. The impeller and hub incorporate an anti-weed system that prevents weed entangling around the impeller shaft. Once the chamber around the impeller shaft and bore have filled with water, very little or no silt will enter the bearings.

1.2 OPERATIONAL USE

The flowmeter may be used in two different ways according to operational requirements, and equipment supplied:

- A. Wading - where the water depth permits, the operator may use the Meter clamped to the wading rods, wading across the river or stream and making velocity measurements at the required intervals and depths. The centimetre markings on the wading rods permit the Meter to be accurately positioned at the required height in the water column, and also to establish the total water depth to enable profile depths to be calculated.
- B. Suspension - in deeper water the Meter may be suspended from a cable over a bridge or parapet to make the required velocity measurements.

2 ASSEMBLY INSTRUCTIONS

2.1 WADING SET

To assemble:

- i. Remove wading rods from case and screw together.
- ii. Screw rods into base.
- iii. Remove suspension pin from Meter, and slide Meter on to rods, setting at required position.
- iv. Screw on direction knob, adjusting Meter so that the impeller points in the direction indicated by the arrow/dot on the direction knob. This makes operation of the unit easier when the Meter cannot be seen in murky water.
- v. Clip the wading signal cable into the Meter (see Figure 1) and plug the jack connector into the Control Unit.
- vi. Ensure that the battery is connected inside the Control Unit and the Meter is now ready for use.

Refer to Section [Operational Use](#) to learn how to operate the meter and control unit.

2.2 SUSPENSION SET

To assemble:

- i. Remove wading rod locking screw from the Meter body and screw in tailfin.
- ii. Remove suspension pin, slide suspension bar through the Meter and set the bar at the required height using the suspension pin.
- iii. Clip the suspension cable to the top end of the suspension bar using the stainless steel shackle provided, and clip the reed switch assembly into the Meter.
- iv. If a Columbus Sinker Weight is being used, attach this to the bottom of the suspension bar.
- v. Plug the jack connector into the Control Unit, ensure the battery is connected inside the Control Unit and the Meter is ready for use.

The Balance Weight on the tailfin is pre-set for use in fresh water. The Meter should be suspended in the water to be gauged and a check made that the Meter lies horizontally. The balance of the unit may be adjusted by moving the balance weight on the tailfin, using the Allen key provided.

Refer to Section [Operational Use](#) to learn how to operate the meter and control unit.

Non-Valeport Control Units

It is advised that if the revolution counter being used is not of Valeport origin, no more than 5 milliamps are passed through the reed switch, to avoid damage. Valeport cannot accept responsibility for damage incurred when using non-Valeport Control Units

3 MAINTENANCE INSTRUCTIONS

The BFM001 and 002 flowmeters have been designed to require minimum maintenance under normal operating conditions. The Control Unit and wading/suspension cables should require no maintenance other than routine inspection and cleaning. It is recommended that the flowmeter itself is thoroughly washed and cleaned in fresh water after each deployment. If the unit has been used in silt-laden water, the impeller should be removed and the impeller bearings and shaft also washed in clean water. This will significantly extend the life of the impeller and shaft.

On no account should a sharp instrument be used in the cleaning process. For extreme conditions, particularly where there are metallic particles in suspension, impellers with extended skirts are available. Before repacking into the carrying cases, all items should be completely dried to prevent any tarnishing of the equipment whilst in transit or storage. Instructions are detailed below for routine maintenance procedures:

3.1 TO REPLACE AN IMPELLER

Refer to [Figure 1 \(BFM001\)](#) and [Figure 3 \(BFM002\)](#).

3.1.1 TO REMOVE IMPELLER

- i. Unscrew the nose cone of the impeller anticlockwise to remove.
- ii. With a 3mm spanner, hold the nut nearest to the washer, and with another spanner release the other nut.
- iii. Remove both nuts, washer and impeller.
- iv. Clean the hub face and the impeller shaft to remove any silt or dirt.
- v. Check the wear condition of the shaft to ensure the bearing areas are clean and smooth.

If there is significant wear on the shaft, it should be replaced.

3.1.2 TO REPLACE IMPELLER

- i. Stand the meter down on its end face with the shaft pointing upwards, and replace impeller with the nose cone fitted.
- ii. Unscrew the nose cone to allow the impeller to rest against the main body hub face.
- iii. Hold the impeller down against the hub face and slowly screw down the nose cone until it begins to lift the impeller away from the hub face.
- iv. Check that the clearance between the nose cone and the impeller end face is within tolerance (0.5 to 0.75 mm, 0.02 to 0.03 in). If the distance is outside this range, then the shaft will need to be adjusted.
- v. Remove the nose cone and fit the washer and nuts supplied, setting the gap between the washer and front hub of the impeller to 1.5 mm (0.062 in).
- vi. Replace nose cone, checking gap as in item iv. Finger tight only is sufficient; undue force may cause damage.

At no time should any lubricant be applied to the shaft or bearings. The only lubrication needed is given by the water the unit is used in.

3.2 TO REPLACE AN IMPELLER SHAFT

Refer to [Figures 2 \(BFM001\)](#) and [Figure 4 \(BFM002\)](#).

- i. Remove the impeller as described above.
- ii. With a ring spanner, unscrew anti-clockwise the shaft lock nut and remove the shaft.
- iii. Clean main body hub face to remove any silt or dirt.
- iv. With a little Loctite applied to the shaft thread, replace the shaft and tighten the lock nut to give the initial setting of the point of the shaft to the main body hub face.
- v. Refit the impeller as described above, and check that the tolerances are correct.
- vi. If shaft length requires adjusting, remove impeller, slacken lock nut, adjust shaft accordingly and re-tighten.
- vii. Finally, check that pulses are being received by the Control Unit.

3.3 TO REPLACE A REED SWITCH ASSEMBLY

Refer to [Figure 5 - Reed Switch Assembly](#).

- i. Hold reed switch adapter (cable end), unscrew the housing in an anticlockwise direction. If it is tight, a pair of pliers may be used, but great care should be taken.
- ii. When fitting the replacement reed switch assembly, ensure that the 'O' ring is clean and in position.

3.4 TO TEST THE FREE RUNNING OF THE IMPELLER ASSEMBLY

- i. Stand the Meter on a flat surface with the impeller pointing vertically.
- ii. Spin the impeller by hand and observe it slowing down. The time to stop is unimportant, but is normally about 20 seconds.
- iii. The impeller should stop spinning smoothly with no jerking being observed.
- iv. When it stops, a slight tap on the flat surface will allow the impeller to rotate slightly until the magnets come into line.

The above condition applies when the unit is dry and in perfect condition. If the impeller stops spinning suddenly or fails to spin smoothly, the impeller shaft may be bent or the clearances may require adjustment (see [Figures 2/Figure 4](#))

4 OPERATION WITH 0012B CONTROL DISPLAY UNIT

4.1 INTRODUCTION

The Valeport Model 0012B Impeller Current Display Unit is a Real Time Speed display unit, offering user selectable measurement of pulse against time averaging (moving, fixed or free running) for all contact closure current meters, including those of other manufacturers. The 0012B contains calibration details for the Valeport meters BFM001, 002, 004, 007 and 050, and allows calibration coefficients for 4 other meters to be programmed in. User specific names for other meter calibrations can also be entered for ease of user identification.

The 0012B also calculates standard deviation of the measured average data, battery low indicator and optional . A logging facility is also optional, with a solid state memory providing 100 records.

4.1.1 PHYSICAL SPECIFICATION

Size:	244mm (L) x 163mm (H) x 94mm (W)
Weight:	2kg
Material:	Moulded ABS Plastic
Sealed:	IP67 (10 seconds at 0.3 metres)
Strap:	Adjustable Shoulder Strap
Power:	8 'C' cells, providing life of approximately 400 hours (100 hours with backlight)
Temperature:	Operating range, -5 to +50°C.

4.1.2 CONNECTORS

Jack Plug:	For connection to existing Valeport current meters
4-Way Mil Spec:	RS 232 connection for PC. Input for loading of calibration data and output of real time averages or stored data (if logging option is fitted).
Pressure Valve:	Passive waterproof pressure equalising valve, to compensate for changes in temperature.

4.1.3 MEASUREMENT METHODS

4.1.3.1 AVERAGE DATA

The average rates and speeds are computed as follows:

In TIME mode:

The number of whole pulses measured / average time set in seconds

In PULSE mode:

The number of pulses set / measured elapsed time for the pulses

If an average period is terminated early, then the calculation is carried out as follows:

In TIME and PULSE mode:

The number of whole pulses completed / elapsed time for the pulses [measured to 0.001 secs]

4.1.3.2 REAL TIME DATA

The REAL TIME rate and speed are calculated from the time for one pulse, resolved to 0.0001 secs.

In **TIME mode**, the real time is calculated and displayed every second.

In **PULSE mode**, the real time is calculated every pulse but the display is only updated every 0.5 seconds [approx.].

4.1.3.3 STANDARD DEVIATION

The STANDARD DEVIATION [SD] is calculated from real time samples taken during the averaging period (once per second in TIME mode or once per pulse in PULSE mode).

4.1.3.4 AVERAGING MODES

The unit performs one average, on a time or pulse basis. At the end of the average period the unit stops and displays the average and SD, and will commence another averaging period when requested by pressing START.

This is fixed average with automatic restart of average at the end of each period. The average and SD from the previous period are displayed and held during the subsequent period, until updated.

The average and SD are calculated over the last period [pulses or time as set], and is updated every second or pulse as appropriate. In TIME mode the display update is every second, but in PULSE mode the fastest display update is about every 0.5 secs, although the calculation may be done more quickly. When STOP is selected, the display is frozen at the last average that has been computed.

If the measurement period is terminated prematurely (by pressing the STOP key), the average values and standard deviation will be calculated from the last measurement parameter (pulses in PULSE mode, seconds in TIME mode).

4.1.3.5 DATA OUTPUT

In fixed average a data string of average data is outputted at the end of averaging period.

In moving average the last saved average is outputted when the user presses the STOP key.

In free running mode the data is outputted at the end of each fixed average period and when the user presses the STOP key.

The data string includes meter type, rev/sec, speed, standard deviation, pulses, time.

5 OPERATION

5.1 SWITCH ON

ON Switch unit On using ON button. This is acknowledged by a beep from the unit. This key is also used to toggle the unit Off at any point during operation. Switching the unit On causes the following display to appear:

```

    I M P E L L E R   C U R R E N T   M E T E R   D I S P L A Y   M E T E R
          V A L E P O R T           M O D E L   0 0 1 2 B
                V E R S I O N       3 . 0 0
< < < O P T I O N S   S E T U P                               C O N T I N U E > > >
  
```

OPTIONS SET-UP This key selects the OPTIONS SETUP menu, which allows the user to set up various hardware configurations (Logging On/Off [optional], Beeper On/Off and Backlight On/Off [optional]). This menu also allows access to the USER CALIBRATION menu, and to the LOGGING SETUP menu. For further information refer to Section: [Options Menu](#)

CONTINUE Places the unit in Run Mode. See Section: [Running the Model 0012B](#)

5.2 RUNNING THE MODEL 0012B

Pressing **CONTINUE** at the title screen, or pressing **EXIT** at any of the OPTION SET-UP screens (see Section: [Options Menu](#)) reveals one of the six possible displays shown below, depending on what mode the unit was in when last used.

DISPLAY 1: FIXED AVERAGE, USER SET TIME DISPLAY:

```

          F I X E D   A V E R A G E       M E T E R   T T T T T T
    X X X           S S S   S E C S   X X X X   P U L S E S           S T O P > > >
      R E A L       A V E R A G E                               S E T U P > > >
    X X . X X       X X . X X       R / S E C                   S D = X . X X X   S T A R T > > >
    X . X X X       X . X X X       M / S E C                   L O W   B A T T
  
```

DISPLAY 2: FIXED AVERAGE, USER SET PULSE COUNT DISPLAY:

```

          F I X E D   A V E R A G E       M E T E R   T T T T T T
    X X X . X X   S E C S           X X X   P P P   P U L S E S           S T O P > > >
      R E A L       A V E R A G E                               S E T U P > > >
    X X . X X       X X . X X       R / S E C                   S D = X . X X X   S T A R T > > >
    X . X X X       X . X X X       M / S E C
  
```

DISPLAY 3: MOVING AVERAGE, USER SET TIME DISPLAY:

MOVING AVERAGE		METER		TTTTTT
XXX	SSS	SECS	XXXX	PULSES
REAL	AVERAGE			STOP >>>
XX.XX	XX.XX	R / SEC		SETUP >>>
X.XXX	X.XXX	M / SEC	SD = X.XXX	START >>>

DISPLAY 4: MOVING AVERAGE, USER SET PULSE COUNT DISPLAY:

MOVING AVERAGE		METER		TTTTTT
XXX.XX	SECS	XXX	PPP	PULSES
REAL	AVERAGE			STOP >>>
XX.XX	XX.XX	R / SEC		SETUP >>>
X.XXX	X.XXX	M / SEC	SD = X.XXX	START >>>

DISPLAY 5: FREE RUNNING, TIME DISPLAY:

FREE RUNNING		METER		TTTTTT
XXX	SSS	SECS	XXXX	PULSES
REAL	AVERAGE			STOP >>>
XX.XX	XX.XX	R / SEC		SETUP >>>
X.XXX	X.XXX	M / SEC	SD = X.XXX	START >>>

DISPLAY 6: FREE RUNNING, PULSE COUNT DISPLAY:

FREE RUNNING		METER		TTTTTT
XXX.XX	SECS	XXX	PPP	PULSES
REAL	AVERAGE			STOP >>>
XX.XX	XX.XX	R / SEC		SETUP >>>
X.XXX	X.XXX	M / SEC	SD = X.XXX	START >>>

An explanation of the different averaging modes can be found in section: [Measurement Methods](#)

- SETUP** Press this key to alter current sampling regime. See Section: [Setting Up Running Mode](#).
- START** Unit will begin sampling in mode currently set. The real time data will be displayed at the bottom of the screen, and a count of either pulses or seconds displayed at the top. If the unit is in logging mode, the current record number will be displayed at the top right hand side of the screen. If the data interface lead is connected, the end of average values will also be sent to the PC.
- STOP** Press to cease sampling. This will force an early end to an averaging period
- LOW BATT** When there is 10 hours of battery life remaining (with backlight), this message will be displayed at the bottom right hand corner of the screen (see DISPLAY 1 for an example). The message will remain until batteries are replaced

5.3 SETTING UP RUNNING MODE

Selecting SET-UP in the Run Menu reveals the following display.

```

                RUN MENU SETUP
<<< M / S E C   F T / S E C                               M E T E R >>>
<<< F I X E D   M O V I N G   F R E E                       A C C E P T >>>
<<< P U L S E S   T I M E           P P P   P U L S E S   C H A N G E >>>
    
```

A further example screen is shown below.

```

                RUN MENU SETUP
<<< M / S E C   F T / S E C                               0 0 2   >>>
<<< F I X E D   M O V I N G   F R E E                       A C C E P T >>>
<<< P U L S E S   T I M E           S S S   S E C S           C H A N G E >>>
    
```

- | | |
|-------------------|---|
| M/SEC FT/SEC | Toggles between measuring the Speed in metres and feet per second. |
| FIXED MOVING FREE | Toggles the averaging mode between the three states. Refer to Section: Measurement Methods for further details. |
| PULSES TIME | Toggles the averaging period counting mode between pulses and seconds. |
| CHANGE | Allows access to the CHANGE SAMPLING menu, which enables the user to alter the number of seconds or pulses in the averaging period. See Section: Changing Sampling Period . |
| METER | The type of meter currently selected is displayed here. Toggle between the available meters by pressing the key. Pre-programmed meters available are the BFM001, 002, 004 (19mm), 004 (28mm), 007 & 050. For details of how to program the calibration details of another meter, refer to Section: Options Menu . |
| ACCEPT | When the sampling regime is correctly set up, press this key to return to the RUN menu (Section: Running the Model 0012B). |

5.4 CHANGING SAMPLING PERIOD

Selecting CHANGE in the Sampling Set-up screen reveals one of the following displays, depending on whether pulses or seconds have been selected for the sampling regime.

```

                C H A N G E   S A M P L I N G
<<< 1 0 0 " S
<<< 1 0 " S           I N C R   D E C R >>>
                P P P   P U L S E S
<<< 1 " S                               E X I T >>>
    
```

```

                CHANGE SAMPLING
<<< 100 " S
<<< 10 " S          INCR  DECR >>>
                SSS SECONDS
<<< 1 " S          EXIT >>>
    
```

- INCR DECR Toggles between increasing and decreasing the number of seconds/pulses when the relevant key is pressed.
- 100'S Changes the number of 100's of pulses/seconds in the averaging period.
- 10'S Changes the number of 10's of pulses/seconds in the averaging period.
- 1's Changes the number of 1's of pulses/seconds in the averaging period.
- EXIT Returns to the RUN MENU SETUP screen.

5.5 OPTIONS MENU

Pressing OPTIONS SET-UP at the Title Screen reveals the following display.

```

                OPTIONS MENU
<<< LOGGING YES / NO          LOGGING MENU >>>
<<< BEEPER ON / OFF          USER CAL >>>
<<< BACKLIGHT ON / OFF      EXIT >>>
    
```

- LOGGING YES/NO Optional. If fitted, this key switches the logging facility On and Off. Up to 100 records may be stored.
- BEEPER ON/OFF Toggles audible acknowledgment of pulses On and Off.
- BACKLIGHT ON/OFF Optional. If backlight is fitted, this key toggles it On and Off. Refer to Section: [Physical Specification](#) for details of battery life with and without backlight.
- LOGGING MENU Allows access to LOGGING MENU (if option fitted). This enables the user to view or erase stored data, to extract it to a PC (via data interface lead), and to set the unit date and time. Proceed to Section: [Logging Menu](#)
- USER CAL Allows access to USER CALIBRATION MENU. This enables the user to read or input their own calibration coefficients or impeller name. Proceed to Section: [User Calibration Coefficients](#)
- EXIT Puts the unit into Run Mode, using the hardware configurations selected (see Section: [Running the Model 0012B](#)).

5.6 LOGGING MENU

Selecting LOGGING MENU at the OPTIONS MENU reveals the following display.

```

LOGGING MENU
< < < S E T   D A T E / T I M E           E X T R A C T   D A T A > > >
< < < R E S E T   # I D E N T           E R A S E   M E M O R Y > > >
< < < V I E W   D A T A                       E X I T > > >
  
```

- SET DATE/TIME Allows access to the CHANGE DATE/TIME screen. This allows the user to alter the unit's internal clock, for the purpose of correctly time stamping the recorded data. See Section: [Change Date\Time](#)
- RESET #IDENT Sets the memory pointer to record #1. The next record that is logged will be #1, replacing what was stored there before.
- VIEW DATA Allows user to see logged data. See Section: [Viewing Stored Data](#)
- EXTRACT DATA Allows user to upload stored data to a PC. See Section: [Extracting Data](#)
- ERASE MEMORY Clears all stored data from the unit. A screen will appear, requesting confirmation that the user wishes to erase memory. Press YES to continue, or EXIT to return to LOGGING MENU. If YES is pressed, a message will confirm that memory has been erased. Press EXIT to return to LOGGING MENU.
- EXIT Returns user to OPTIONS MENU. Refer to Section: [Options Menu](#)

5.6.1 CHANGE DATE\TIME

Selecting SET DATE/TIME at the LOGGING MENU reveals the following display.

```

CHANGE DATE / TIME
< < < N E X T           I N C R E A S E > > >
T I M E :   H H : M M           D E C R E A S E > > >
D A T E :   D D / M M / Y Y Y Y
                                           E X I T > > >
  
```

- INCREASE Increases the currently selected number by 1.
- DECREASE Decreases the currently selected number by 1.
- NEXT Selects the next number in the time/date sequence.
- EXIT Returns user to LOGGING MENU. Refer to Section: [Logging Menu](#)

5.6.2 VIEWING STORED DATA

Selecting VIEW DATA at the LOGGING MENU reveals a display similar to that shown below. If no data has been stored, the message NO DATA STORED will be displayed.

```
# I D E N T    1 2
I M P E L L E R   T Y P E    0 0 2                U P > > >
U N I T S   M E T R E S
R U N   M O D E   F I X E D   A V E R A G E   T I M E    D O W N > > >
3 1 / 1 2 / 1 9 9 9   2 3 : 5 9 : 5 9
< < < V I E W                                E X I T > > >
```

The display shows the record number, impeller type, units in which velocity is measured (metres or feet per second), run mode, and time at which the record was stored.

- UP** Toggles the record to be viewed up by one.
- DOWN** Toggles the record to be viewed down by one
- EXIT** Returns to the LOGGING MENU. Refer to Section: [Logging Menu](#)
- VIEW** Allows user to view the record currently selected. A display of the format shown below will be seen. Press EXIT on this screen to return to the VIEW DATA screen, allowing another record to be seen.

```
# I D E N T    X X
r e v / s e c   X X . X X
s p e e d       X . X X X
s t d   d e v   X . X X X
p u l s e s     X X X X
t i m e        X X X . X
                                E X I T > > >
```

5.6.3 EXTRACTING DATA

Selecting EXTRACT DATA at the LOGGING MENU reveals the following display.

```
                                E X T R A C T   D A T A
                                                                U P L O A D > > >
                                P L E A S E   C O N N E C T   P C
                                                                E X I T > > >
```

Connect the unit to a PC via the data interface lead supplied. Run a terminal emulation program on the PC, ensuring that communications are correctly set to 4800 baud, 8 data bits, 1 stop bit, no parity bits. If the data should be saved, make sure that the data is directed to a file name. It is uploaded as a text file, so can be read into a word processor or spreadsheet application.

- UPLOAD** Begins to upload data to PC. Screens similar to those shown below will appear
- EXIT** Returns to LOGGING MENU. Refer to Section: [Logging Menu](#)

```

                U P L O A D I N G   D A T A

                # I D E N T       X X
    
```

When data uploading is finished, the following screen appears, showing the #IDENT of the last record to be uploaded.

```

                F I N I S H E D   U P L O A D I N G   D A T A

                # I D E N T       X X

                                E X I T > > >
    
```

EXIT Returns to LOGGING MENU. Refer to Section: [Logging Menu](#)

5.7 USER CALIBRATION COEFFICIENTS

Selecting USER CAL at the OPTIONS MENU reveals the following display.

```

                                S E T   U S E R   C A L > > >
                                R E A D   U S E R   C A L > > >

                                E X I T > > >
    
```

READ USER CAL Allows the user to read the name and calibration coefficients of the currently selected impeller. Proceed to Section: [Reading Calibration Coefficients](#)

SET USER CAL Allows the user to install the name and calibration coefficients of a new meter. See Section: [Setting Calibration Coefficients](#)

EXIT Puts the unit into Run Mode. Refer to Section: [Running the Model 0012B](#)

5.8 READING CALIBRATION COEFFICIENTS

Selecting READ USER CAL reveals the calibration data of the meter currently selected in the sample mode. The format of the screen depends on the type of calibration used. Below are examples of LINE FIT and POLYNOMIAL FIT displays.

```
LINE FIT                IMPELLER TYPE
SLOPE 1                OFFSET 1
END 1                  SLOPE 2
OFFSET 2              END 2
SLOPE 3              OFFSET 3
END 3                  SLOPE 4
OFFSET 4              END 4                EXIT >>>
```

```
POLYNOMIAL FIT        IMPELLER TYPE
COEFF 7              COEFF 6
COEFF 5              COEFF 4
COEFF 3              COEFF 2
COEFF 1              COEFF 0
                                EXIT >>>
```

EXIT Puts the unit into Run Mode. Refer to Section: [Running the Model 0012B](#)

5.9 SETTING CALIBRATION COEFFICIENTS

Selecting SET USER CAL reveals the following display.

```
PLEASE CONNECT EXTERNAL PC
```

Connect a PC to the Model 0012B using the data interface lead.

Using a terminal emulation program, program in the required calibration coefficients using the control codes and format detailed below:

The Model 0012B will not be able to display speed data if the pulse output from the impeller exceeds 50Hz. The operating ranges of all Valeport impellers fall well within this, but if inputting calibration data for a different meter, check that the expected pulse frequency is below 50Hz. If a larger frequency is anticipated, contact Valeport Limited.

5.10 REPLACEMENT IMPELLER (ORANGE NOT YELLOW)

We have recently completed a redesign of the 001 and 106 impellers to make them easier to manufacture. As a result, from the 1st February 2024 we will be switching over to the new parts, with no change in performance. All customers will notice is a difference in colour with the new impeller being orange rather than yellow.

If you require a replacement impeller to an existing instrument, please contact sales@valeport.co.uk. The instrument will need its factory calibration string updated. This can easily be done by a simple app which can be provided by Valeport Support support@valeport.co.uk.

New part numbers:

0001SA2-2024 New 001/106 Impeller & 0001SA5-2024 New 001/106 nose cone assembly

5.10.1 GENERAL CONTROL CODES #000 - #014

Code	Followed By space and	Operation	Access
#000		Exit calibration set-up mode	All
#001	New calibration string<cr>	OTHER 1 IMPELLER Changes calibration to New_calibration string sent must be to the required format using spaces as separators	All
#002	New calibration string<cr>	OTHER 2 IMPELLER Changes calibration to New_calibration string sent must be to the required format using spaces as separators	All
#003	New calibration string<cr>	OTHER 3 IMPELLER Changes calibration to New_calibration string sent must be to the required format using spaces as separators	All
#004	New calibration string<cr>	OTHER 4 IMPELLER Changes calibration to New_calibration string sent must be to the required format using spaces as separators	All
#011	New name string<cr>	OTHER 1 IMPELLER Changes the name of other 1 impeller from other 1 to new name string - for ease of user identification.	All
#012	New name string<cr>	OTHER 2 IMPELLER Changes the name of other 2 impeller from other 2 to new name string - for ease of user identification.	All
#013	New name string<cr>	OTHER 3 IMPELLER Changes the name of other 3 impeller from other 3 to new name string - for ease of user identification.	All
#014	New name string<cr>	OTHER 4 IMPELLER Changes the name of other 4 impeller from other 4 to new name string - for ease of user identification.	All

5.10.2 TABLE 1: CALIBRATION FUNCTION NUMBERS AND MEANING

Calibration Function No.	OPERATION	DEFINED
0	Not defined	NO
1	Straight line fit	YES
2	Polynomial fit	YES

5.10.3 HOW TO PROGRAM CALIBRATION COEFFICIENTS.

First, decide if your calibration is a polynomial equation or a series of straight line fits. For line fits, proceed to Section: [Straight Line Fits](#). For polynomial fits, proceed to Section: [Polynomial Fits](#).

5.10.3.1 STRAIGHT LINE FITS.

In a terminal emulation program (for example TERMINAL in Windows), set the communications to 4800 baud, 8 data bits, 1 stop bit, 0 parity bits. Also, check that the correct comms port on the PC is being used. If necessary, check that the Local Echo is On, or you will not be able to see what you are typing appear on the screen.

With the 0012B CDU connected to the PC via the interface lead provided, select USER CAL from the OPTIONS MENU and then SET USER CAL. Check the PC connection.

In the terminal emulation program, the message 'Enter Calibration Data' appears.

The calibration data should then be entered as follows:-

```
#CODE Ident_number Coefficient1 Offset1 Max_It1 Coefficient2 Offset2 Max_It2 Coefficient3  
Offset3 Max_It3 Coefficient4 Offset4 Max_It4<cr>
```

where

- #CODE = the set calibration function code (from Section: [General Control Codes](#))
- Ident_number = Calibration Function No. For a line fit, this will be 1. (See Table 1 above).
- Coefficient = slope of the line.
- Offset = the line constant
- Max_It = the end point beyond which the present straight line parameters no longer operate

All straight line fits are considered to be four line fits, and therefore sufficient coefficients must always be entered to ensure correct calculation of the calibration factor. For line fits less than four line fits the unused parameters should be filled in with zeros.

For example, the calibration for the BFM001 is a two straight line fit, with equations:

$$V = 0.013 + 0.2512n \text{ (up to 0.32 revs/sec)}$$

$$V = 0.008 + 0.2667n \text{ (from 0.32 up to 11.28 revs/sec)}$$

where V is velocity in m/s and n is revolutions per second.

To enter this calibration in OTHER3, the following would be typed. Note the space after each number:

```
#003 1 0.2512 0.013 0.32 0.2667 0.008 11.28 0 0 0 0 0 0
```

To change the name of the meter, type the correct #CODE followed by the new name (upper and lower cases are recognised). For example, to change the name from OTHER3 to BFM001, enter:

```
#013 BFM001
```

When all required data has been input, enter #000, and the 0012B will automatically return to the Options Menu.

5.10.3.2 POLYNOMIAL FITS.

In a terminal emulation program (for example TERMINAL in Windows), set the communications to 4800 baud, 8 data bits, 1 stop bit, 0 parity bits. Also, check that the correct comms port on the PC is being used. If necessary, check that the Local Echo is On, or you will not be able to see what you are typing appear on the screen.

With the 0012B CDU connected to the PC via the interface lead provided, select USER CAL from the OPTIONS MENU and then SET USER CAL. Check the PC connection.

In the terminal emulation program, the message 'Enter Calibration Data' appears.

The calibration data should then be entered as follows:-

```
#CODE Ident_number C7 C6 C5 C4 C3 C2 C1 C0<cr>
```

where

#CODE = the set calibration function code see Section: [General Control Codes](#)

Ident_number = Calibration Function No. For a polynomial fits, this will be 2. (See Table 1 above).

C<number> = X Coefficient factor

$$(X7 * C7) + (X6 * C6) + (X5 * C5) + (X4 * C4) + (X3 * C3) + (X2 * C2) + (X1 * C1) + C0$$

All polynomial fits are considered to be seventh order fits (i.e. of the format above), and therefore sufficient coefficients must always be entered to ensure correct calculation of the calibration factor. For polynomial fits less than seventh order, the unused parameters should be filled in with zeros.

For example, your calibration equation may be:

$$V = 0.001n^5 + 0.003n^4 + 0.6n^3 + 7.03n^2 + 0.6n + 4.1$$

where V is velocity in m/s and n is revolutions per second.

To enter this calibration in OTHER3, the following would be typed. Note the space after each number:

```
#003 2 0 0 0.001 0.003 0.6 7.03 0.6 4.1
```

To change the name of the meter, type the correct #CODE followed by the new name (upper and lower cases are recognised). For example, to change the name from OTHER3 to BFM001, enter:

```
#013 BFM001
```

When all required data has been input, enter #000, and the 0012B will automatically return to the Options Menu.

6 FLOWMETER SPARES

Valeport maintains full spares, service and repair facilities for all its instruments. In the event of spares or additional items being required, the main sub-assemblies and spare parts are detailed below.

BFM0011	Current meter fitted with 127 mm dia. x 0.27m pitch impeller
BFM0021	Current meter fitted with 50 mm dia. x 0.1m pitch impeller
BFM0012B	Real time velocity and revolution counting control unit
BFM0013	Set of 3 stainless steel wading rods, each 0.5m long, graduated in cms with base plate and direction knob
BFM0014	2m long wading cable fitted with reed switch for BFM001 and jack plug
BFM0024	2m long wading cable fitted with reed switch for BFM002 and jack plug
BFM0016	Current meter tail-fin 0.75m long with balance weight
BFM0017	35m conductor/suspension cable (breaking strain 100 Kg) fitted with reed switch for BFM001 and jack plug assemblies
BFM0027	35m conductor/suspension cable (breaking strain 100 Kg) fitted with reed switch for BFM002 and jack plug assemblies
BFM0018	Suspension bar
BFM0010/1	BFM001 impeller
BFM0020/1	BFM002 impeller
BFM0010/2	Impeller shaft for BFM001 c/w nuts and washer
BFM0020/2	Impeller shaft for BFM002 c/w nuts and washer
BFM0010/4	Reed switch assembly for BFM001
BFM0020/4	Reed switch assembly for BFM002
BFM0010/5	Additional wading rod
BFM0015	Carrying case for wading set
BFM0019S2	Carrying case for suspension set
BFM0019S1	Carrying case for wading and suspension set
BFM001/M	Operating and instruction manual incl. calibration chart

For spare parts not listed above, please consult the factory. Valeport recommend that all equipment is returned to the factory for all service or repairs. Please refer to the Guarantee Certificate for our terms regarding the return of equipment.

7 FIGURES

7.1 FIGURE 1 - SECTIONAL DIAGRAM BFM001

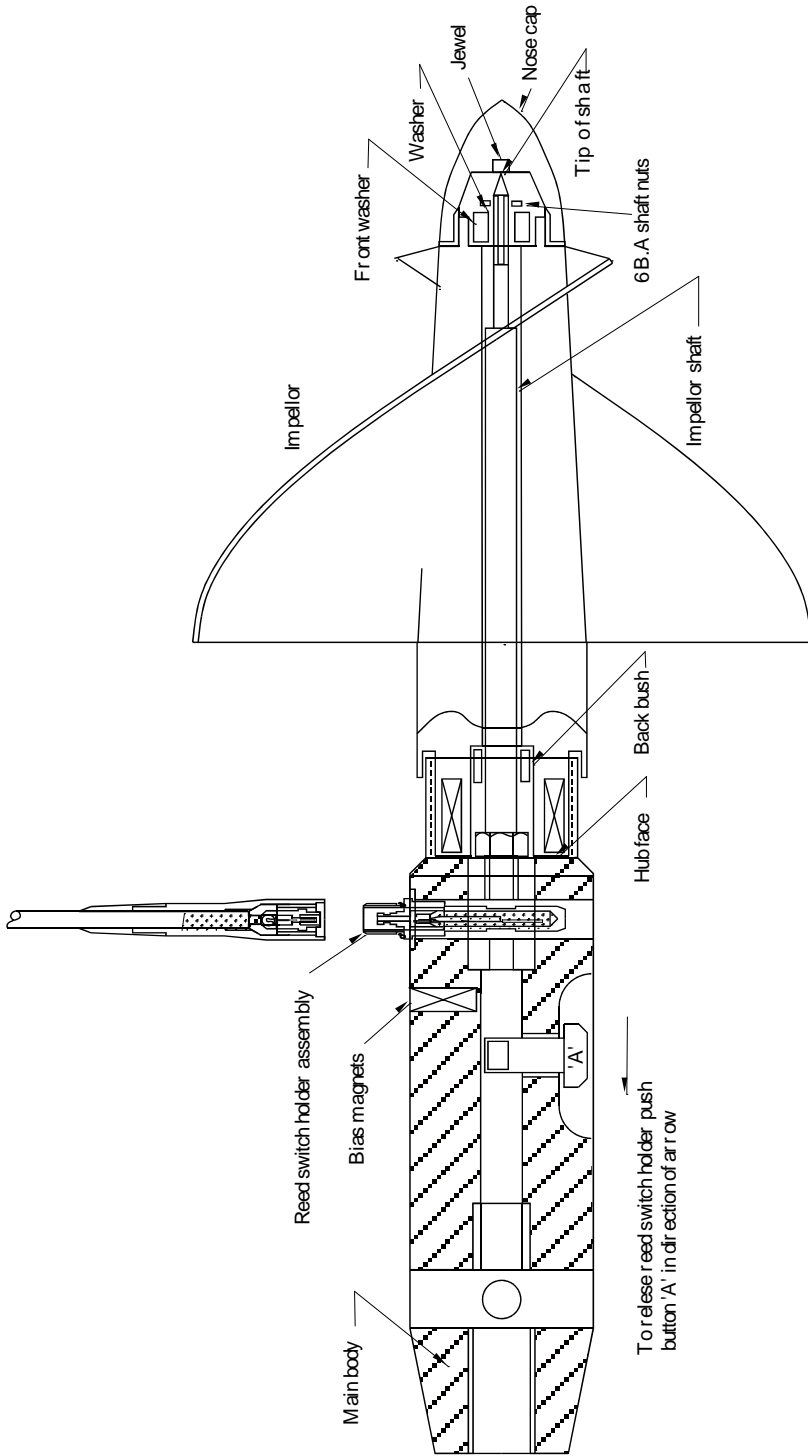

Figure 1 – Sectional Diagram BFM001

7.2 FIGURE 2 - BFM001 IMPELLER SHAFT SETTING

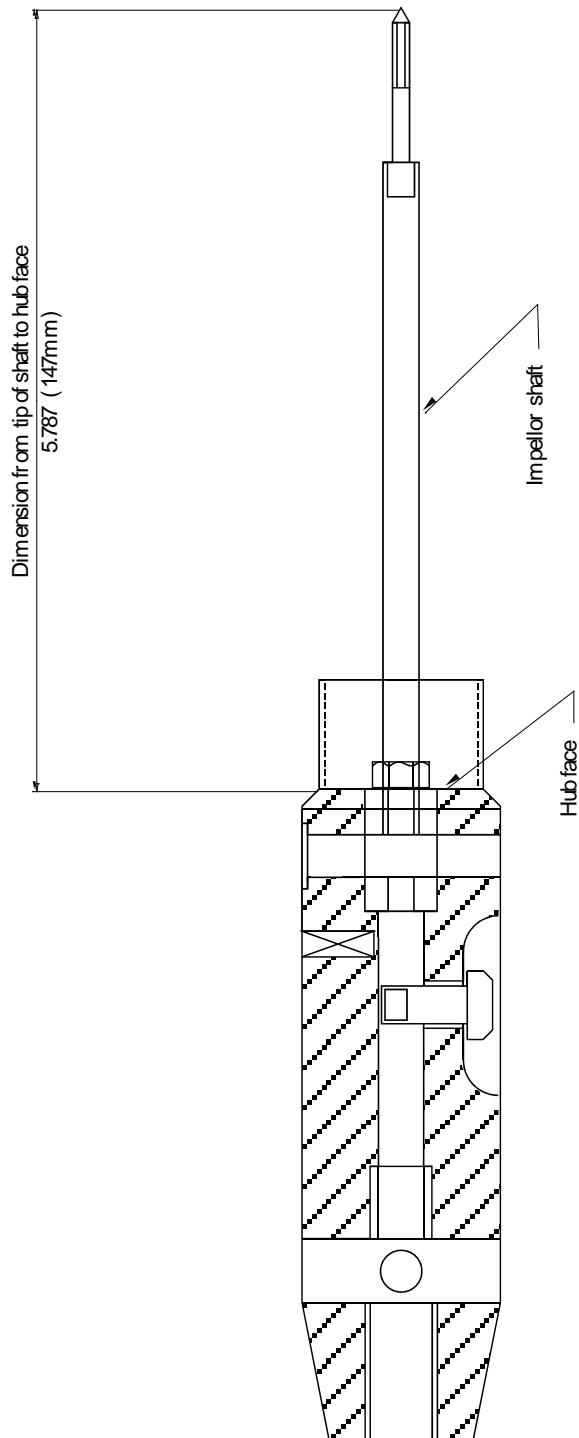

Figure 2 – BFM001 impeller shaft setting

7.3 FIGURE 3 - SECTIONAL DIAGRAM OF BFM002

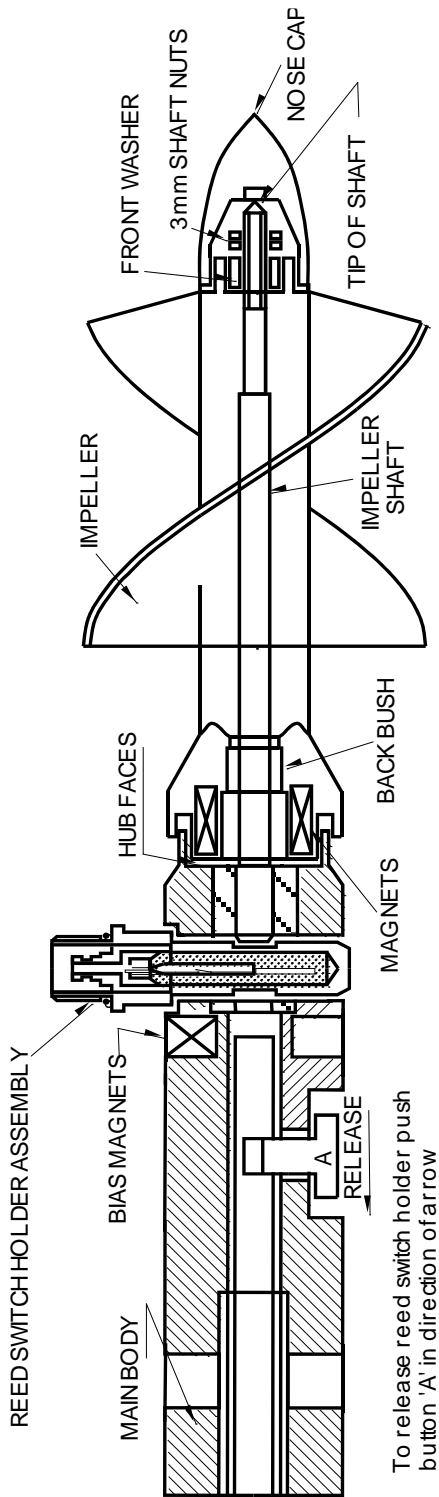

Figure 3 – sectional diagram of BFM002

7.4 FIGURE 4 - BFM002 IMPELLER SHAFT SETTING

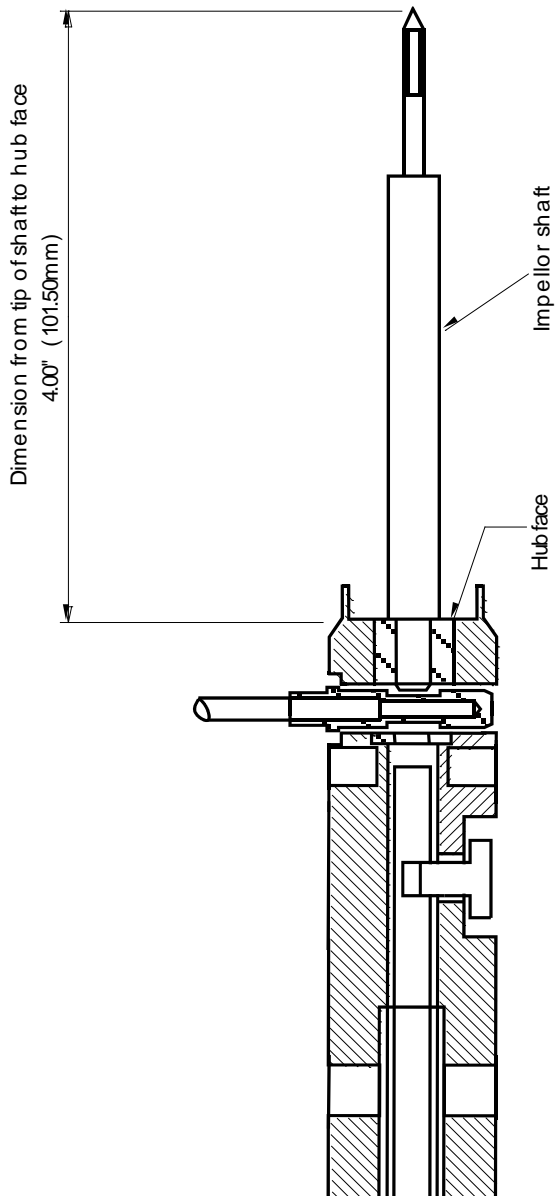

Figure 4 – BFM002 impeller shaft setting

7.5 FIGURE 5 - REED SWITCH ASSEMBLY

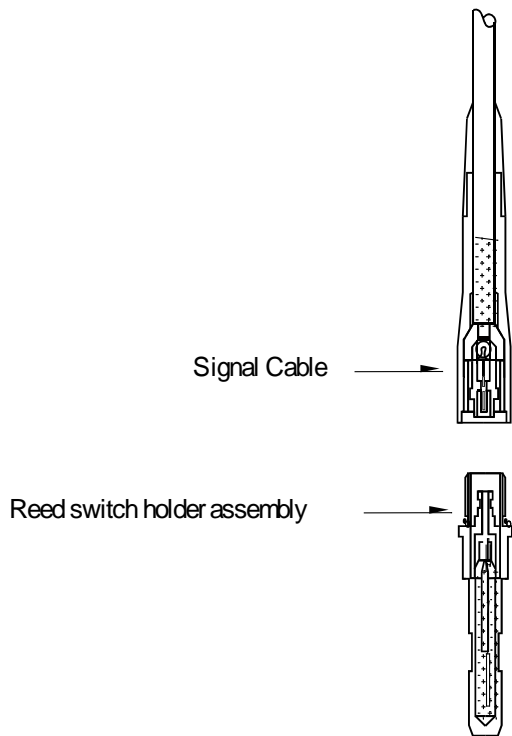



Figure 5 – reed switch assembly

8 EU DECLARATION OF CONFORMITY - CE MARKING

Any changes or modifications to the product or accessories supplied, that are not authorised by Valeport Ltd, could void the CE compliance of the product and negate your authority to operate it. This product has demonstrated CE compliance under conditions that include the use of shielded cables. It is important that you use shielded cables compliant with the product’s conformance, to protect from potential damage and reduce the possibility of interference to other electronic devices



EU Declaration of Conformity

Manufacturer:	Valeport Ltd
Address:	St Peter’s Quay, Totnes, Devon, TQ9 5EW
Certification marking:	CE
Product Description:	001 & 002 Open channel flow meters

We the manufacturer declare that the products 001 & 002 Flow Meters, are in conformity with the following EU Directives and harmonised standard(s):

EMC Directive 2014/30/EU	Standards
EMC (Article 3.1b)	BS EN 61326-1:2013 (Basic Level)





RoHS Directive 2011/65/EU	Standards
Prevention (Article 4.1)	BS EN 50581:2012

Name:	Jason Horsell
Position:	Development Engineer
Place of issue:	Valeport Ltd, Totnes, UK
Date of issue:	12 February 2019
Signature:	

Valeport Limited
St. Peter’s Quay, Totnes,
Devon TQ9 5EW UK

+44 (0) 1803 869292
sales@valeport.co.uk
www.valeport.co.uk

VAT No: GB 165 8753 67
Registered in England No. 1950444

APPENDICES

A-1 Group Calibration of the 8011 Series Impeller

As fitted to the Valeport "Braystoke" BFM001 flowmeter

A-1.1 Definition

The calibration given here is not that of any individual meter, but one synthesised from tests carried out at the Hydraulics Research Station, Wallingford, UK in March 1981 on a sample batch of 19 instruments with rod suspension. The calibration is based upon standards set by the British Standards Institution, BS3680, Part 8A, 1973.

A-1.2 Application

It applies to the BFM001 Meter fitted with the 125 mm (5 inch) diameter impeller, but only those fitted with the 8011 series impeller, introduced from June 1981. A systematic error would result if the calibration were applied, incorrectly, to any other type of Valeport meter.

A-1.3 Recognition

The prefix number 8011 is marked on the trailing edge of the impeller blades, together with the individual serial number of the impeller. The 8011 series may also be recognised by:

- i. the blades taper in thickness from root to tip (some earlier meters had blades of uniform thickness).
- ii. a 'land' or 'step' about 3mm wide on the impeller hub, forward to the leading edge of the blades (on the preceding 475 series, the root of the impeller blade leading edge is flush with the forward end of the hub).

A-1.4 Rating Equations and Table

Speed of Rotation, n (rev/s)		Speed of Flow, V (m/s)		
Min	Max			
0.07	0.32	0.013 + 0.2512 n		Equation 1
0.32	11.28	0.008 + 0.2667 n		Equation 2

Equation 1 extends from 0.031 to 0.093 m/s.

Equation 2 extends from 0.093 to 3.016 m/s.

These equations are evaluated in the attached ready-reference Calibration Chart, which covers the full range of the general calibration.

Limited tests have shown that the calibration may be extended to about 18 rev/sec (5 m/s) without significant loss of precision. The Calibration Chart is extended to include flow speeds up to 5 m/s.

The BFM001 may also be used successfully at flow speeds in excess of 5 m/s. The flow speed should be calculated from the Rating Equation. There may however be a significant variation from

the computed flow speed and it is recommended that, if the Meter is to be used regularly at flow speeds in excess of 5 m/s, an individual calibration of the Meter is undertaken.

A-1.5 Reliability

Over most of the flow speed range, above about 0.15 m/s, any particular BFM001 meter with 8011 type Impeller is expected (at 95 per cent confidence level) to perform within ± 1.5 per cent of the indication of the group calibration. At very low flow speeds, although the uncertainty remains small in absolute terms, it increases rapidly if considered as a percentage of the flow speed being measured. The following table illustrates this.

Flow Speed (m/s)	3.00	2.00	1.00	0.50	0.25	0.15	0.10	0.07	0.03
Uncertainty (m/s)	0.045	0.023	0.011	0.005	0.004	0.002	0.002	0.003	0.004
%	1.5	1.2	1.1	1.1	1.5	1.4	2.3	4.4	14.0

It is particularly important therefore, not to extrapolate the first equation of the group calibration below the stated lower limit.

A-1.6 Individual Calibration

If the uncertainty levels shown above are higher than desirable for a particular application of the meter, then it should be calibrated individually. However, there will still be the unavoidable tolerance which exists with any calibration process. If the meter is to be used mainly with cable suspension, individual calibration may also be justified.

A-1.7 Further Details

The method of deriving the group calibration, together with detailed results, is given in Report No. DE53 Calibration B1/2 'Group Calibration for the Braystoke Type BFM001 Current Meter with 8011 Series Impeller June 1981' of the Hydraulics Research Station, Wallingford, Oxon OX10 8BA, UK.

A-2 Group Calibration of the 1178 Series Impeller

As fitted to the Valeport "Braystoke" BFM002 flowmeter

A-2.1 Summary

It is customary to calibrate current meters individually, which is expensive and time consuming. For a family of physically identical meters a less costly and generally satisfactory alternative is a group calibration. This is synthesised from the performance of a sample batch or group of meters and indicates the average performance of the entire family.

The following Group Calibration B2/2 has been derived for the Braystoke type BFM002 current meter with 50 mm impeller, which became available from early 1978. Subsequently, the impellers carried the reference number 1178. The calibration is based on tests of 20 meters, all on 20 mm diameter rod suspension, in the meter rating tank at the Hydraulics Research Station over the period June 1976 to February 1982.

Speed of Rotation, n (rev/s)		Speed of Flow, V (m/s)	
Min	Max		
0.26	0.97	$0.034 + 0.0991 n$	Equation 1
0.97	4.71	$0.023 + 0.1105 n$	Equation 2
4.71	27.86	$0.039 + 0.1071 n$	Equation 3

The limiting values of rotation speed correspond to flow speeds of 0.060, 0.130, 0.543 and 3.023 m/s respectively. The equations are evaluated as a ready reference rating table, see following pages.

The tolerance, or uncertainty, of computed flow speed using the above group calibration compared with the measured flow speed at the same rotation speed is approximately constant in percentage terms above 0.5 m/s. The value then does not exceed 2.2% at the 95% confidence level. However, at lower speeds the percentage uncertainty is much greater. In this range it is more realistic to consider the uncertainty in terms of absolute speed; the value is near constant around 0.01 m/s at speeds between 0.06 and 0.50 m/s.

The current meter should not be used at speeds below about 0.15 m/s if avoidable, due to the wide uncertainty at low speed.

A Preliminary Group Calibration for the Braystoke BFM002 Current Meter was printed by the former Water Data Unit of the Department of the Environment as an un-numbered research paper in October 1980. It was derived from tests of 11 meters. The present report includes 10 of these results supplemented by others from a further 10 meters; the rating equations given above replace the preliminary group calibration which should not be used.

A-2.2 Method and Result of Group Calibration

A-2.2.1 Extract from Full Report.

The minimum and maximum values of rotation speed, within which the equation should be restricted, had now to be determined. The minimum value represents the minimum response speed of the group of current meters, which is by definition the limit of predictable low-speed performance. Extrapolation beyond this point would be unreliable, so it was necessary to choose a conservatively high value of minimum response speed to allow for the individual meter which may have a particularly high minimum response speed. For the group of 20 meters tested, the mean value of minimum response speed was 0.046 m/s, with standard deviation of 0.0046 m/s. The highest value measured was 0.054 m/s. Since the value of (Mean +3 x Standard Deviation), which may be expected to include 99.8% of all meters, was 0.060 m/s and exceeds the highest measured value, a minimum response speed of 0.060 m/s was accepted. From the relevant equation this flow speed corresponds to a rotation speed of 0.26 m/s.

All the meters except three were run to a maximum speed of about 3m/s, the exact value varying from test to test. However, the choice of an upper limit for the group calibration is less critical than the lower limit, as a well-designed meter has an extended near-linear performance at higher speeds. Earlier work with a Braystoke meter showed that if a flow speed at 4.9 m/s was computed from a rating equation whose upper limit was 2.8 m/s, the result was only 1.1% in error. Hence, the upper limit of flow speed adopted was chosen, by inspection, to include 95% of the measured values below it. This limiting value was 3.023 m/s, corresponding to a rotation speed of 27.86 m/s.

In view of the above comments the HRS calibration tables have been extended to include all values of rotation speeds, from 0.12 to 46.32 corresponding to a range of flow speeds from 0.046 to 5.000 m/s

A-2.2.2 Acknowledgements

The above summary, report extract and following calibration tables are reproduced from HRS Report No. DE57 (Calibration B2/2), June 1982 with the kind permission of Hydraulics Research Station, Wallingford, England. For a full detailed description of the group calibration, please refer to this report.